

JACK

China No.1

Shanghai stock
listed

A3B

High Speed Computerized Lockstitch Machine

New update,
More stable

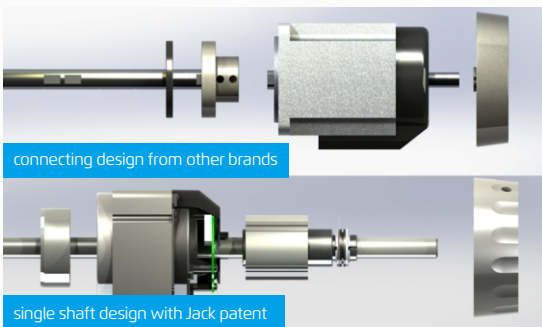

Advantages

1. Single Shaft Design With Stable Performance

Lighter machine torque for fast, stable and durable sewing performance.

2. For Heavy Duty And Light Fabrics

Suitable for various of fabrics like jeans and yarn.

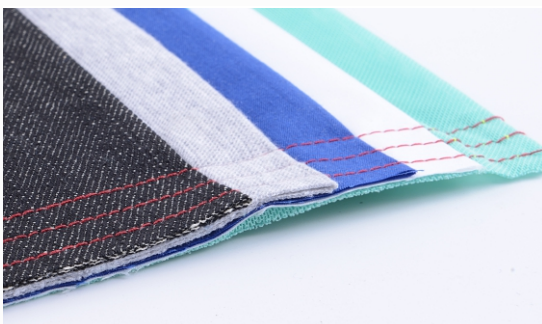

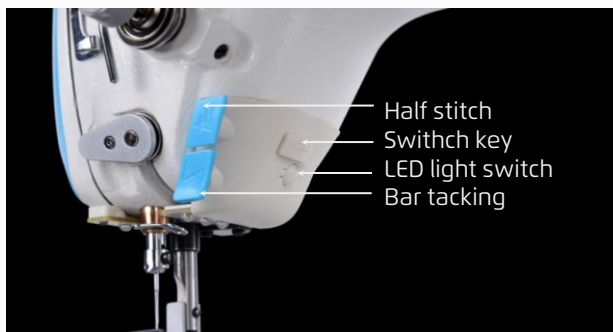

Humanized Design

Factory Reset

One key back to the factory reset.

Comparison Table

Model	Puncture Force (A4 papers)	Noise	Vibration	Thread Lose Prevention Rate In Start Sewing	Voltage Range	Machine Accuracy	Trial Sewing For Elastic, Knitted Material	Stopping time
A3B-A	100 layers	75.7dB	98μm	98%	120-275Vac	Billions invested Automatic Processing line	beautiful stitches	195ms
A2S	92 layers	77.2dB	150μm	87%	120-275Vac	Ordinary lathe processing	beautiful stitches	250ms

Technical parameters

Model	Needle Size	Thread Number	Max Stitch Length (mm)	Presser Foot Lifter Height (mm)	Max Speed (s.p.m)	Thin thick	medium thick	Thick material	Volume (mm)	Weight (kg)
A3B-A-C	Db×111-18#	2	5	5-13	5000	√	√		695×295×550	36/42

JACK TECHNOLOGY CO.,LTD

ADD:No.1008, Donghai Avenue East, Jiao jiang District, Taizhou City, Zhejiang Province, China
TEL:0086-576-88177782

E-mail: sales@chinajack.com
www.chinajack.com